

LED BLASTER 108

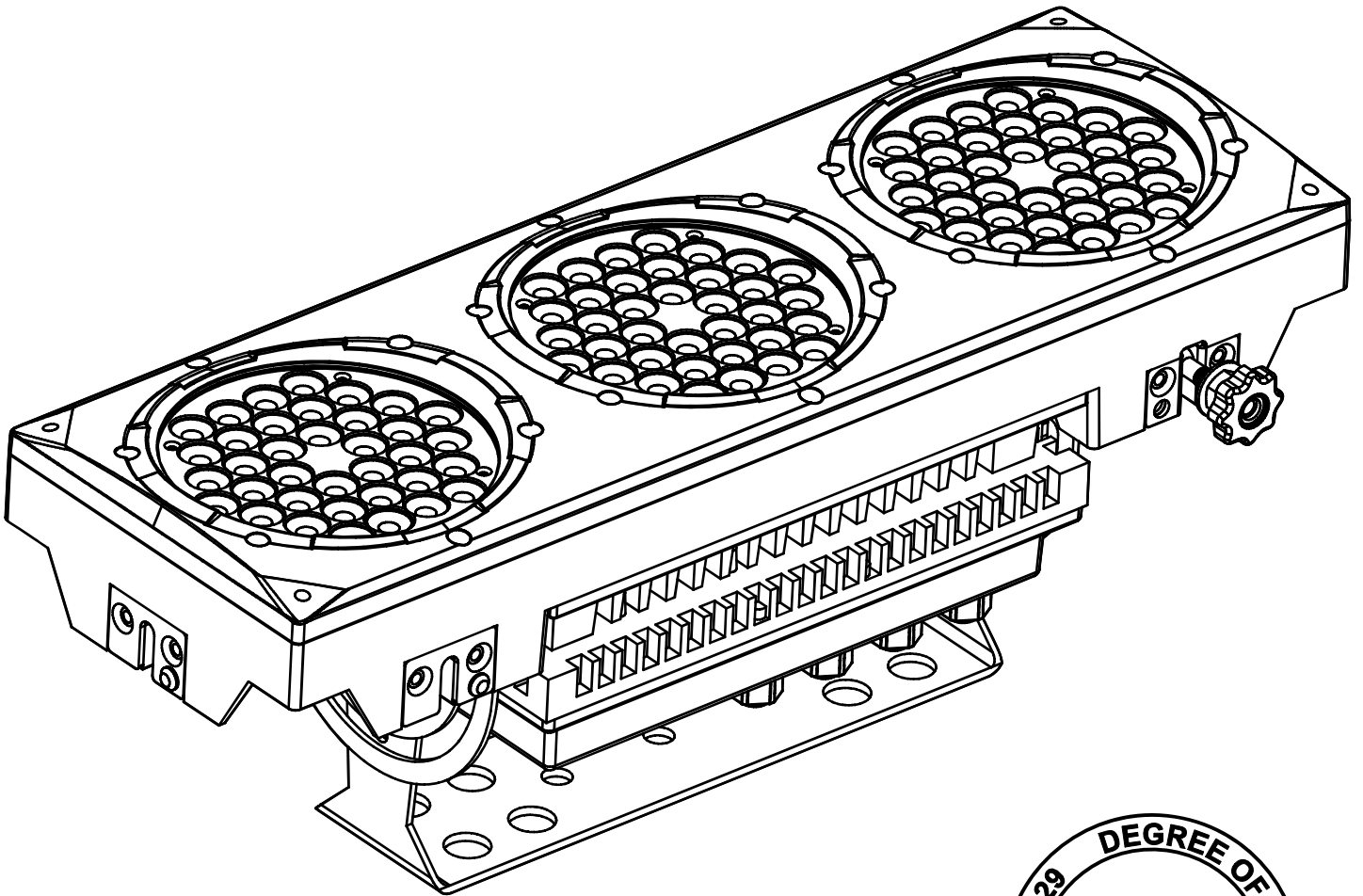

VIDEO PROOF
400 Hz
SCAN RATE



USER
MANUAL
Ver 1,0

WWW.BRITEQ-LIGHTING.COM

T ABLE OF CONTENTS

PART 1 PRODUCT (GENERAL)	1.
1.1-- <i>PRODUCT INTRODUCTION</i>	1.
1.2-- <i>PRODUCT FEATURES</i>	1.
1.3-- <i>TECHNICAL SPECIFICATIONS</i>	2.
1.4-- <i>PHOTOMETRIC DATA</i>	3.
1.5-- <i>SAFETY WARNING</i>	4.
PART 2 INSTALLATION	5.
2.1-- <i>MOUNTING</i>	5.
2.2-- <i>POWER CONNECTION</i>	5.
2.3-- <i>INTERLOCKING MULTIPLE FIXTURES</i>	6.
2.4-- <i>SETTING UP WITH A DMX512 CONTROLLER</i>	7.
2.4-1-- <i>DMX512 ADDRESSING WITHOUT ID ADDRESSING(STAGE 1 MODE)</i>	7.
2.4-2-- <i>DMX512 ADDRESSING WITH ID ADDRESS(STAGE 1 MODE)</i>	7.
2.4-3-- <i>ADAS WITH ID ADDRESS(STAGE 1 MODE)</i>	8.
PART 3 DISPLAY PANEL OPERATION	9.
3.1-- <i>BASIC</i>	9.
3.2-- <i>MENU</i>	10.
3.3-- <i>CREATING A STATIC COLOR</i>	11.
3.4-- <i>DMX512 SETTINGS</i>	11.
3.5-- <i>DMX CHANNEL MODE</i>	11.
3.6-- <i>RUN MODE</i>	11.
3.7-- <i>ACTIVATING AN AUTO PROGRAM</i>	12.
3.8-- <i>CHANGING THE SETTINGS</i>	12.
3.9-- <i>ACTIVATE THE PASSWORD</i>	13.
3.10-- <i>POWER ON/OFF</i>	13.
PART 4 USING A DMX512 CONTROLLER	14.
4.1-- <i>BASIC ADDRESSING</i>	14.
4.2-- <i>CHANNEL ASSIGNMENT</i>	14.
4.3-- <i>BASIC INSTRUCTIONS FOR DMX512 OPERATION</i>	23.
4.4-- <i>PROGRAMMING WITH A DMX512 CONTROLLER: EXAMPLES</i>	26.
PART 5 APPENDIX	30.
5.1-- <i>TROUBLE SHOOTING</i>	30.

1 PRODUCT (GENERAL)

1.1 PRODUCT INTRODUCTION

This product is designed for indoor or outdoor use. Suitable applications include wash or effect lighting for architectural, stage or nightclub applications. This product can also be installed for use in signage and advertising using the dynamic functions available with DMX512 control. Direct input of DMX512 signal allows the units to be controlled from any DMX512 controller. This product can be operated as a single unit or in multiple units for large applications.

The specially developed controller that allows the product to be controlled independent of the DMX512 controller enables the user to create and edit a wide range of custom programs. All programs can be touch-button displayed or scheduled to START and END at scheduled times. When programs have been created or edited in the controller, it is also possible to trigger these programs using the DMX IN function when connected to a DMX512 controller.

1.2 PRODUCT FEATURES

LED FIXTURE

- * RGB Dimmer 0-100%
- * Strobe
- * Individual control of each LED group
- * Automatic programs
- * IP65 protection rating
- * LCD display
- * Display control 'lock-out'
- * Direct DMX512 input
- * Automatic DMX512 and ID Addressing
- * Independant ID address
- * Overheat protection (showing "warning heat")
- * Lightweight aluminium casing
- * Black anti-UV plastic cover
- * Interlocking-module system

1.3 TECHNICAL SPECIFICATIONS

LED MODULE

LED MODULE:	
Voltage	100~240V...50/60Hz
Rated Power	150W
IP	IP65 protection rating
LED/Unit	108pcs (36 x RED / 36 x GREEN / 36 x BLUE)
Output/LED	1W
Cooling	Direct air convection
Dimensions	570 x 220 x 190mm
Weight	13Kg

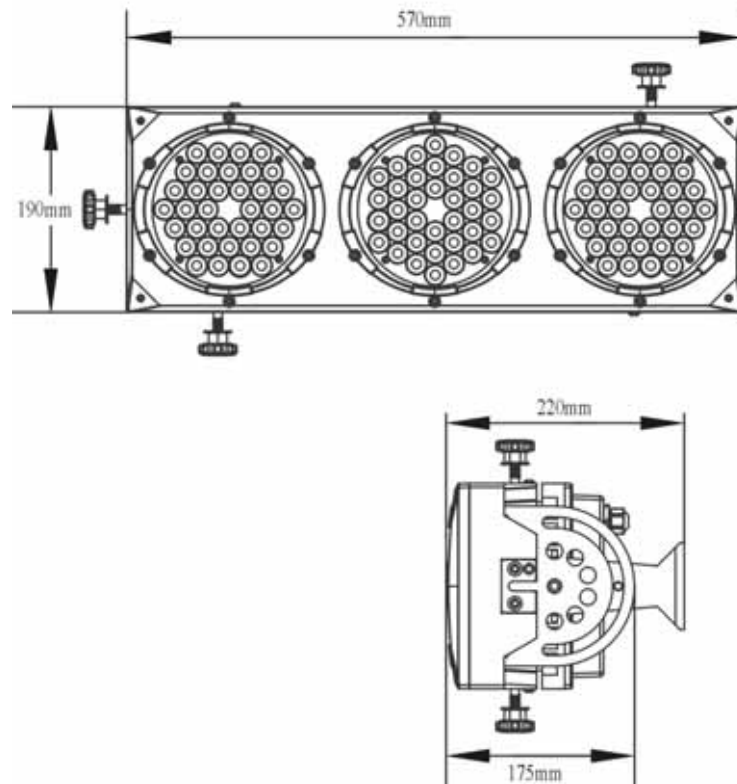

1.4 PHOTOMETRIC DATA

PHOTOMETRIC DATA

RGB 100%

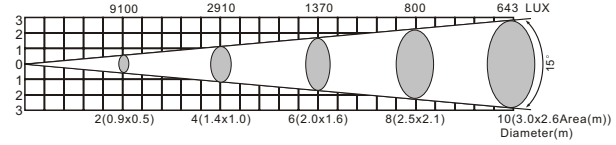

WHITE

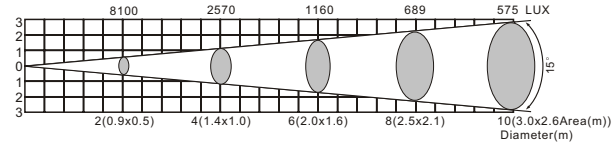

RED

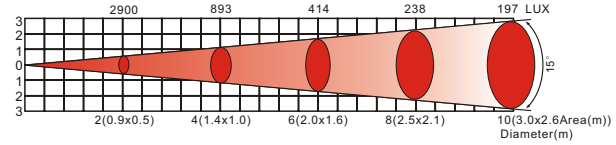

GREEN

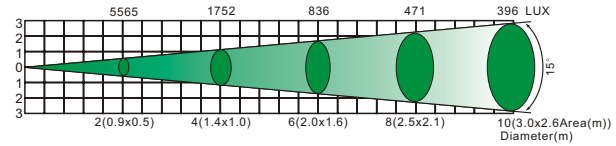

BLUE

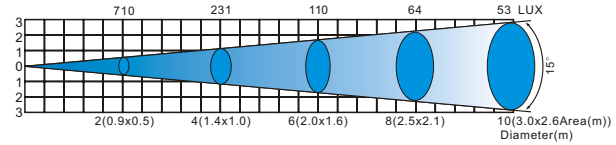

1.5 SAFETY WARNING

IMPORTANT

**[ALWAYS READ THE USER MANUAL BEFORE OPERATION.]
[PLEASE CONFIRM THAT THE POWER SUPPLY STATED ON THE
PRODUCT IS THE SAME AS THE MAINS POWER SUPPLY IN YOUR
AREA.]**

- This product must be installed by a qualified professional.
- Always operate the equipment as described in the user manual.
- A minimum distance of 0.5m must be maintained between the equipment and combustible surface.
- The product must always be placed in a well ventilated area.
- Always make sure that the equipment is installed securely.
- DO NOT stand close to the equipment and stare directly into the LED light source.
- Always disconnect the power supply before attempting and maintenance.
- Always make sure that the supporting structure is solid and can support the combined weight of the products.
- The earth wire must always be connected to the ground.
- Do not touch the power cables if your hands are wet.

ATTENTION



- This product left the place of manufacture in perfect condition. In order to maintain this condition and for safe operation, the user must always follow the instructions and safety warnings described in this user manual.
- Avoid shaking or strong impacts to any part of the equipment.
- Make sure that all parts of the equipment are kept clean and free of dust.
- Always make sure that the power connections are connected correct and secure.
- If there is any malfunction of the equipment, contact your distributor immediately.
- When transferring the product, it is advisable to use the original packaging in which the product left the factory.
- Shields, lenses or ultraviolet screens shall be changed if they have become damaged to such an extent that their effectiveness is impaired.
- The lamp (LED) shall be changed if it has become damaged or thermally deformed.

2 INSTALLATION

2.1 MOUNTING

HANGING

The LED MODULE can be mounted in a hanging position using the support frame. It is possible to use any bolt of the correct size and strength to mount the fixture. It is recommended to use at least 2 mounting points per fixture. Mounting with a clamp or other mounting bracket is recommended depending on the requirements of your application. For overhead use, always install a secure-chain that can hold at least 10 times the weight of the fixture. You must only use safety-ropes with screw-on carabines. Pull the safety-rope through the aperture on the the base's metal frame. Insert the end in the carabine and tighten the fixation screw. (See picture on right)

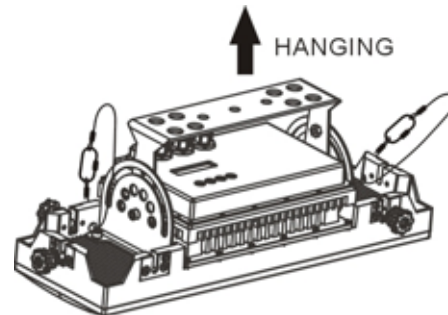

UPRIGHT

The LED MODULE can be mounted upright using the support frame. It is possible to use any bolt of the correct size and strength to mount the fixture. It is recommended to use at least 2 mounting points per fixture. Mounting with a clamp or other mounting bracket is recommended depending on the requirements of your application.

UPRIGHT

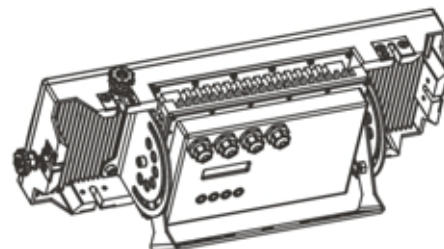

NOTE

The LED MODULE can be mounted at any angle and in any position. It is possible to further adjust the angle of the LED MODULE using the two adjustment knobs located on the side of the fixture.

2.2 POWER CONNECTIONS

@ 220~240V: 15 units may be connected in series

@100~120V: 8 units may be connected in series

2.3 INTERLOCKING MULTIPLE FIXTURES

The diagram above shows how multiple units can be interlocked together to create a 'panel' or 'blinder' arrangement.

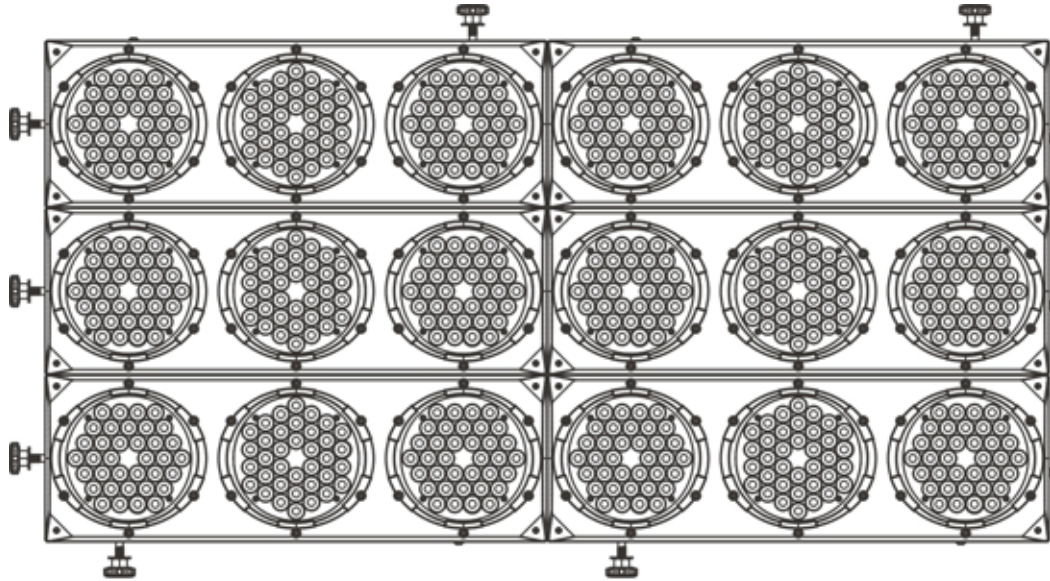

The 'male' and 'female' connections enable the fixtures to be interlocked together in the way shown in the diagram. Please note that when multiple units are mounted together it is not necessary to attach every single unit to the truss, wall or weight supporting system. However, it is important to ensure that all fixtures are securely locked together and that each fixture is secured using a safety cable.

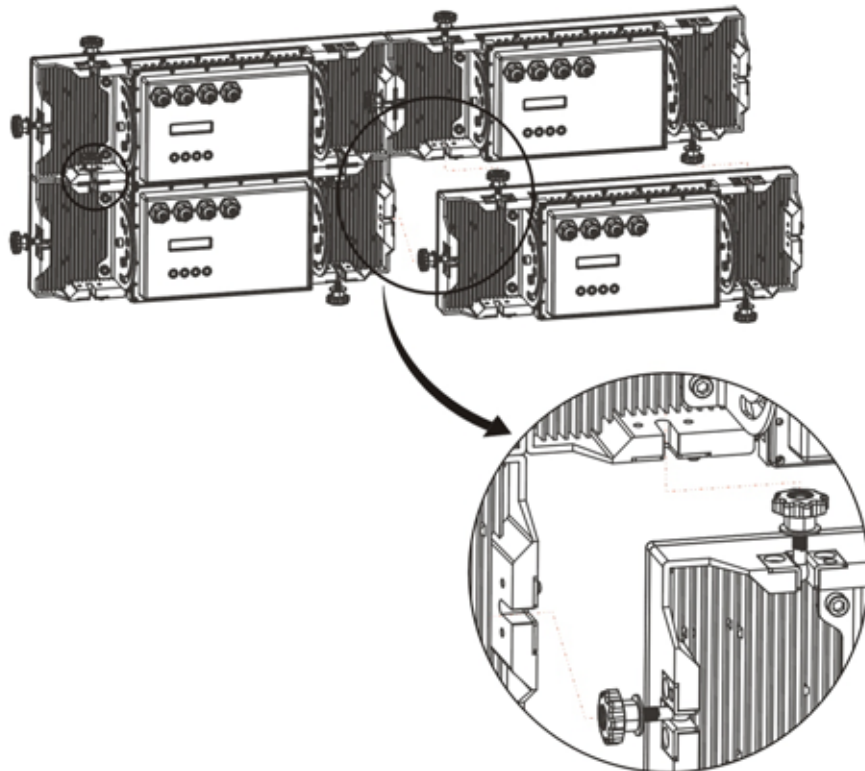

2.4 SETTING UP WITH A DMX512 CONTROLLER

2.4-1 **DMX512 ADDRESSING WITHOUT ID ADDRESSING (STAGE 1 MODE)**

- Connect the DMX512 controller to the units in series.
- Each unit has 12 DMX channels so the DMX Addresses should increase by increments of 12 (e.g. 1,13,25,37...)
- The ID address has not been set so therefore when using the controller CH10 must be inactive (CH10=0).
- It is also possible to deactivate ID address selecting **[ID OFF]** from the **[Settings]** menu on the fixture.
- Each DMX Address may be used as many times as required.
- Any DMX address in the range from 001 to 245 may be used.

Example:

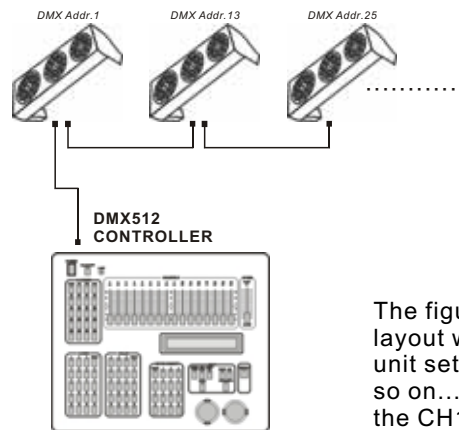

The figure above shows a simple DMX512 layout with the starting address of the first unit set at 1, with the second set at 13 and so on... (Note that when used in this way, the CH10 ID function must be inactive (CH10=0))

2.4-2 **DMX512 ADDRESSING WITH ID ADDRESS (STAGE 1 MODE)**

- Connect the DMX512 controller to the units in series
- Each unit has 12 DMX channels so the DMX Addresses should increase by increments of 12 (e.g. 1,13,25,37...)
- Each DMX Address may be used as many times as required.
- Any DMX address in the range from 001 to 245 may be used.
- Each DMX address may carry up to 66 separate ID addresses.
- **[ID Address]** should be set in the **[Settings]** menu on each unit in ascending values (i.e. 1,2,3...)
- **[ID On]** should be set in the **[Settings]** menu on each unit.
- ID addresses are accessible from CH10 on the DMX512 controller.

Example:

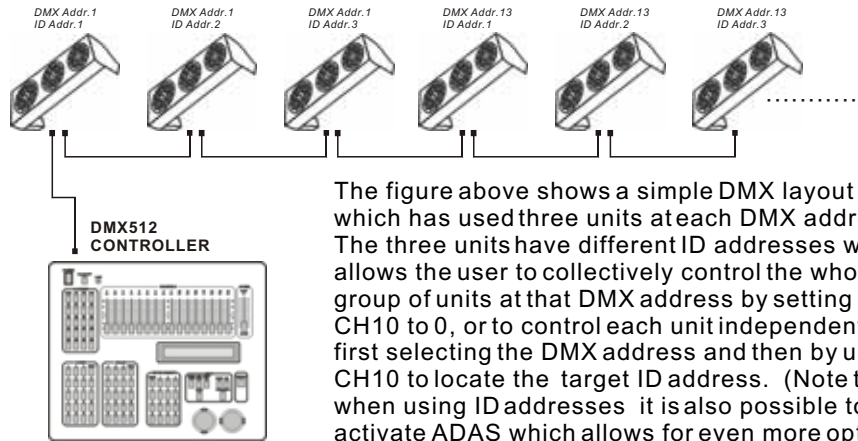

The figure above shows a simple DMX layout which has used three units at each DMX address. The three units have different ID addresses which allows the user to collectively control the whole group of units at that DMX address by setting CH10 to 0, or to control each unit independently by first selecting the DMX address and then by using CH10 to locate the target ID address. (Note that when using ID addresses it is also possible to activate ADAS which allows for even more options with DMX addressing and control see ADAS Addressing section 2.2-3)

2.4-3 ADAS WITH ID ADDRESS(STAGE 1 MODE)

- Connect the DMX512 controller to the units in series
- Select **【ADAS ON】** from the **【Settings】** menu
- **【ID Address】** should be set in the **【Settings】** menu on each unit in ascending values (i.e. 1,2,3...)
- ADAS addressing is based on the ID address as follows:
 $ADAS\ DMX\ Address = \{ \text{【 ADAS fader】} * (ID\ Address - 1) \} + 1$
- ADAS addressing is activated by moving CH8 + CH10 faders to the 255 value (CH8 = 255 & CH10 = 255)
- ADAS addressing is deactivated by moving CH8 + CH10 + CH11 to the 255 value (CH8 = 255, CH10 = 255 & CH11 = 255)
- When ADAS is deactivated, all DMX addresses will return to their original DMX Address.
- To permanently store ADAS DMX addresses, select **【ADAS copy】** from the **【Settings】** menu, on the target fixtures to store the new DMX Address.

Example:

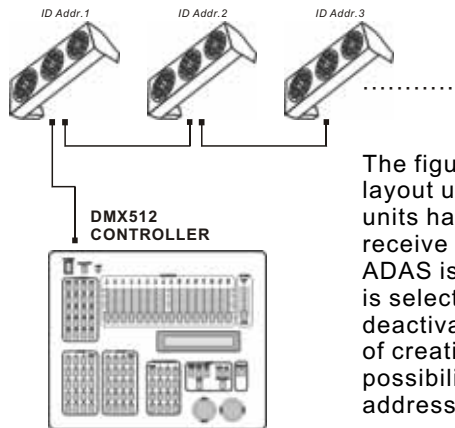

The figure above shows a simple ID address layout using one DMX address. Each of the units has a different ID address which will receive a new temporary DMX address when ADAS is activated (unless **【ADAS copy】** is selected). The user is able to activate and deactivate ADAS at will giving the possibility of creating many different fixture grouping possibilities using the ID address, real DMX address and the ADAS temporary DMX address.

Note:

When using ADAS, all fixtures must have the following settings from the **【Settings】** menu set correctly;

- | | |
|------------------------|--|
| 【ID address】 | Each unit should have the target ID address set in ascending order |
| 【ID ON/OFF】 | Each unit should set 【ID On】 |
| 【ADAS fader no】 | Each unit should be set to the same number of faders as your controller (must be ≥ 12) |
| 【ADAS ON/OFF】 | Each unit should be set as 【ADAS On】 |

3 DISPLAY PANEL OPERATION

3.1 BASIC

The LED fixture is mounted with a LCD display and 4 control buttons.

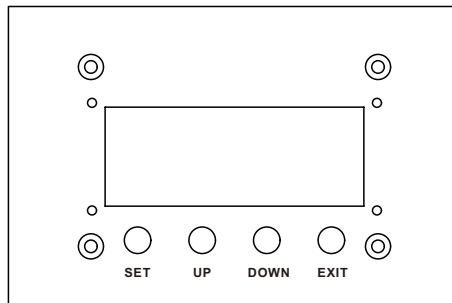

- 【 SET 】** enter the currently selected menu or confirm the current function value
- 【 UP 】** scroll 'UP' through the menu list or increase the value of the current function
- 【 DOWN 】** scroll 'DOWN' through the menu list or decrease the value of the current function
- 【 EXIT 】** exit from the current menu or function

3.2 MENU

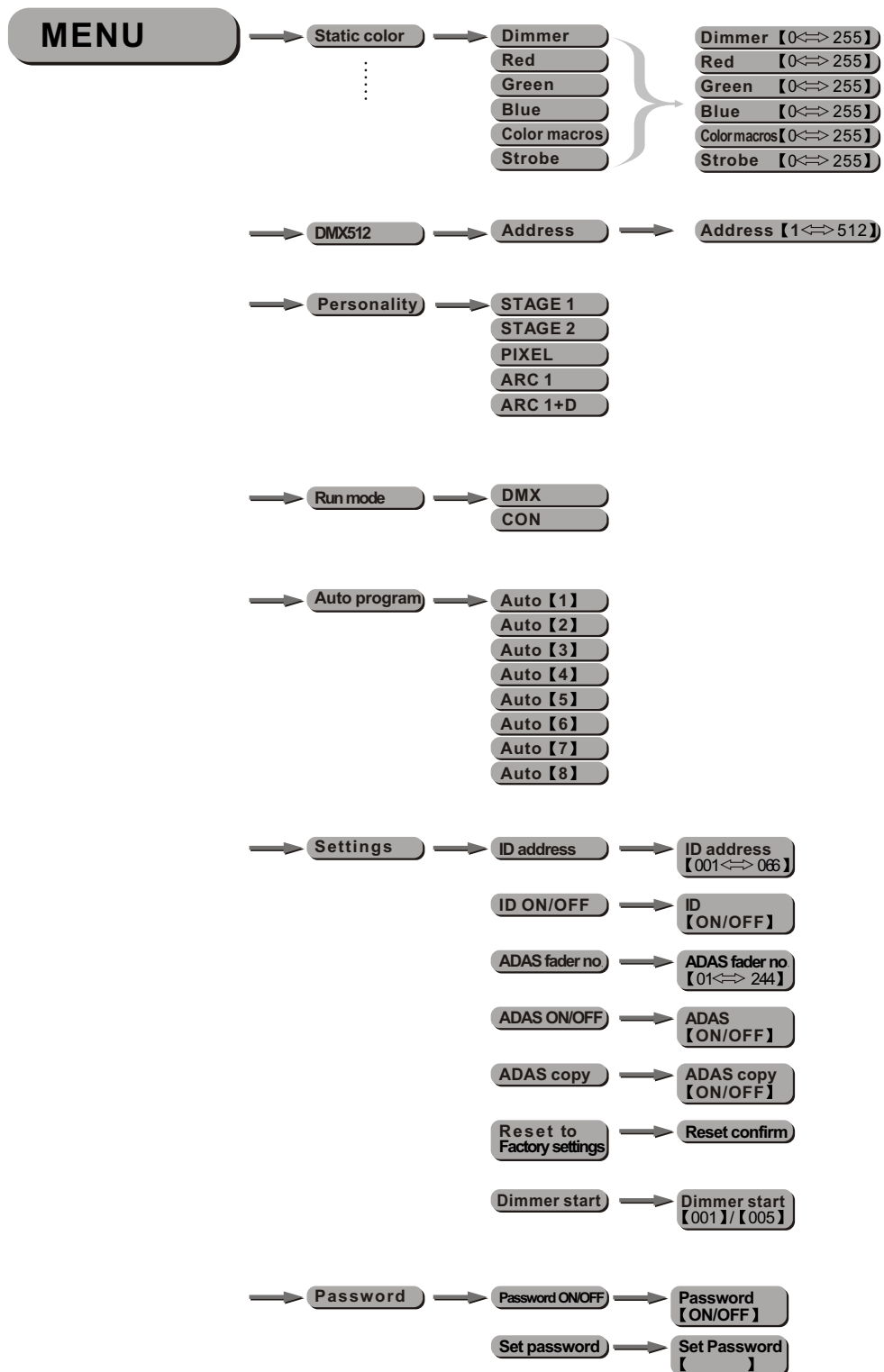

3.3 CREATING A STATIC COLOR

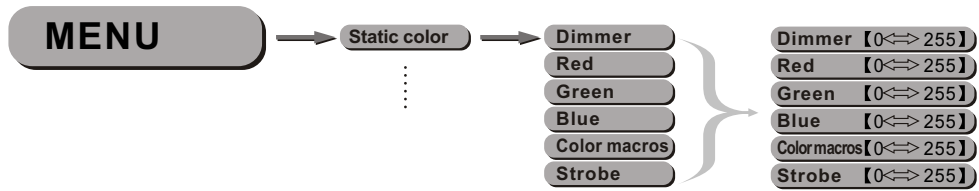

【Static colour】

- Combine RED, GREEN and BLUE to create an infinite range of colors (0-255)
- Enter **【Color macros】** allow to choose 18 color macros
- Set value of dimmer (0-255)
- Set the value of the strobe (0-20Hz)

3.4 DMX512 SETTINGS



【DMX512 address】

- Enter the **【DMX address】** mode to set the DMX address
- Activate control from outside source by activating ON

3.5 DMX CHANNEL MODE

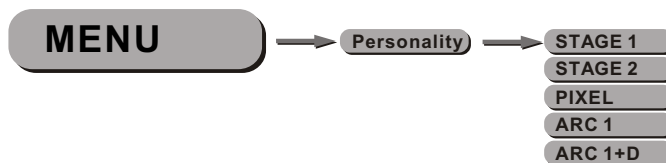

【Personality】

- Enter **【Personality】** mode to choose DMX mode: **【STAGE 1】**, **【STAGE 2】**, **【PIXEL】**, **【ARC 1】** or **【ARC 1+D】**.

3.6 RUN MODE



【Run mode】

- Enter the **【Run mode】** mode to set the working mode
- **【DMX】** mode is for using the DMX512 controller to control the fixtures.
- **【CON】** mode is for using the pix controller to control the fixtures.

3.7 ACTIVATING AN AUTO PROGRAM

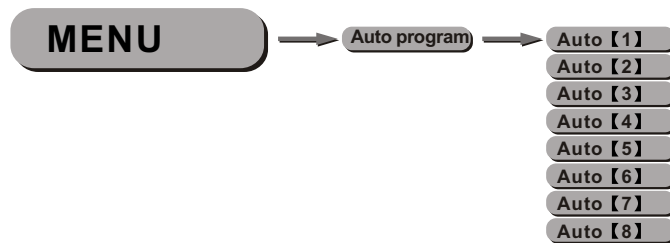

【Auto Program】

- Select the target **【Auto mode】** and press **【Set】** to display

3.8 CHANGING THE SETTINGS

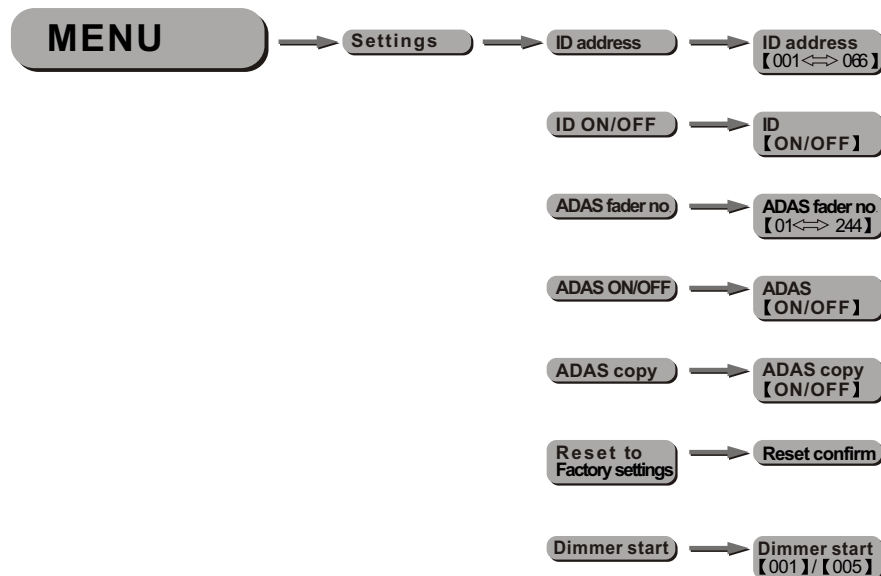

【Settings】

- Enter the **【ID Address】** to set the ID address for the unit
- Enter **【ID ON/OFF】** in order to allow/disallow ID address function from the DMX512 controller
- Enter the **【ADAS fader no】** to set the number of channel faders in each layer of the controller
- In **【ADAS ON/OFF】** select allow/disallow Automatic DMX512 Addressing System (ADAS)
- In the **【ADAS COPY】** menu select whether to allow copy of DMX address to unit after ADAS has assigned new DMX address when ADAS function is activated from the DMX512 controller.
- Enter the **【Reset to Factory Settings】** in order to reset to default factory settings.
- Enter the **【Dimmer start】** to select dimmer start value **【001】** or **【005】**. The default setting is **【005】**.

3.9 ACTIVATE THE PASSWORD

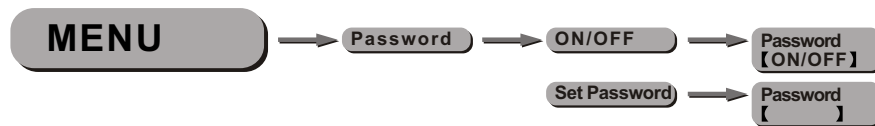

- Enter the **【Password】** mode to set password YES/NO
- When password is activated, display will demand password each time the fixture is powered on.
- Enter the **【Set password】** menu to change password.
- Set new password using the **【UP】** & **【DOWN】** keys.
- Input an 8 digit password and then press **【SET】** to confirm
- NOTE: In the event that the password is forgotten. Please use the factory password shown below.
- **【UP】 > 【DOWN】 > 【UP】 > 【DOWN】 > 【UP】 > 【UP】 > 【DOWN】 > 【DOWN】**

3.10 POWER ON/OFF

- TURN OFF When display shows **【MENU】** , hold down the **【EXIT】** key for 3 seconds to turn off power.
- TURN ON When display is off, hold down the **【EXIT】** key for 3 seconds to turn on power.

4 USING A DMX512 CONTROLLER

4.1 BASIC ADDRESSING

- Connect all of the units in series using standard DMX512 signal cable or the IP65 rated cable provided.
- Set the DMX512 address in the 'DMX512 Address' menu.
- It is possible to have the same DMX address or independent addresses for each fixture.

4.2 CHANNEL ASSIGNMENT

Note:

- This product has four DMX512 channel configurations (**STAGE 1**, **STAGE 2**, **PIXEL**, **ARC 1 & ARC 1+D**).
- Both **STAGE 1** and **STAGE 2** have two DMX modes: **DMX MODE 1** and **DMX MODE 2**
- Ch9 is used to switch from one DMX MODE 1 (**0-244**) to DMX MODE 2 (**245-255**).

ARC 1

CHANNEL	VALUE	FUNCTION
1	0 ↔ 4	RED No function
	5 ↔ 255	0-100%
2	0 ↔ 4	GREEN No function
	5 ↔ 255	0-100%
3	0 ↔ 4	BLUE No function
	5 ↔ 255	0-100%

ARC 1+D

CHANNEL	VALUE	FUNCTION
1	0 ↔ 4	DIMMER No function
	5 ↔ 255	0-100%
2	0 ↔ 4	RED No function
	5 ↔ 255	0-100%
3	0 ↔ 4	GREEN No function
	5 ↔ 255	0-100%
4	0 ↔ 4	BLUE No function
	5 ↔ 255	0-100%

STAGE 1(DMX MODE 1)

CHANNEL	VALUE	FUNCTION
1	0 ↔ 4	RED No function
	5 ↔ 255	0-100%
2	0 ↔ 4	GREEN No function
	5 ↔ 255	0-100%
3	0 ↔ 4	BLUE No function
	5 ↔ 255	0-100%
4	0 ↔ 4	YELLOW No function
	5 ↔ 255	0-100%
5	0 ↔ 4	CYAN No function
	5 ↔ 255	0-100%
6	0 ↔ 4	PURPLE No function
	5 ↔ 255	0-100%
7	0 ↔ 4	WHITE No function
	5 ↔ 255	0-100%
8	0 ↔ 4	STROBE No function
	5 ↔ 255	Strobe (slow to fast)
9	0 ↔ 4	MODE SELECTION No function
	5 ↔ 34	Color-Cycle Mode 1
	35 ↔ 64	Color-Cycle Mode 2
	65 ↔ 94	Color-Cycle Mode 3
	95 ↔ 124	Color-Cycle Mode 4 (speed can be adjusted using Channel 11)
	125 ↔ 154	Color-Cycle Mode 5
	155 ↔ 184	Color-Cycle Mode 6
	185 ↔ 214	Color-Cycle Mode 7
	215 ↔ 244	Color-Cycle Mode 8
	245 ↔ 255	DMX MODE 2

CHANNEL	VALUE	FUNCTION
10	0 ↔ 9	ID ADDRESS SELECTION (also see pg. 26) Select all ID addresses
	10 ↔ 19	ID address #1
	20 ↔ 29	ID address #2
	30 ↔ 39	ID address #3
	⋮	
	200 ↔ 209	ID address #20
	210	ID address #21
	211	ID address #22
	212	ID address #23
	⋮	
	255	ID address #66
	11	0 ↔ 4
5 ↔ 34		#1 ON
35 ↔ 64		#2 ON
65 ↔ 94		#3 ON
95 ↔ 124		#1 ON #2 ON
125 ↔ 154		#2 ON #3 ON
155 ↔ 184		#1 ON #3 ON
185 ↔ 214		#1 ON #2 ON #3 ON
215 ↔ 255		#1 OFF #2 OFF #3 OFF
0 ↔ 255		Speed control of CH9 Color-Cycle Mode 4
12		0 ↔ 4
	5 ↔ 9	Effect MACRO #1
	10 ↔ 14	Effect MACRO #2
	⋮	⋮
	250 ↔ 255	Effect MACRO #50

STAGE 1(DMX MODE 2)

CHANNEL	VALUE	FUNCTION
1	0 ↔ 4	MODULE #1 No function
	5 ↔ 34	RED
	35 ↔ 64	GREEN
	65 ↔ 94	BLUE
	95 ↔ 124	YELLOW
	125 ↔ 154	PURPLE
	155 ↔ 184	CYAN
	185 ↔ 255	PINK-WHITE
2	0 ↔ 4	MODULE #2 No function
	5 ↔ 34	RED
	35 ↔ 64	GREEN
	65 ↔ 94	BLUE
	95 ↔ 124	YELLOW
	125 ↔ 154	PURPLE
	155 ↔ 184	CYAN
	185 ↔ 214	PINK-WHITE
3	0 ↔ 4	MODULE #3 No function
	5 ↔ 34	RED
	35 ↔ 64	GREEN
	65 ↔ 94	BLUE
	95 ↔ 124	YELLOW
	125 ↔ 154	PURPLE
	155 ↔ 184	CYAN
	185 ↔ 214	PINK-WHITE
4		NO FUNCTION
5		NO FUNCTION
6		NO FUNCTION
7		NO FUNCTION
8	0 ↔ 4	STROBE No function
	5 ↔ 255	Strobe (slow to fast)
9	0 ↔ 244	MODE SELECTION DMX MODE 1
	245 ↔ 255	DMX MODE 2

CHANNEL	VALUE	FUNCTION
10	0↔9	ID ADDRESS SELECTION (also see pg. 26) Select all ID addresses
	10↔19	ID address #1
	20↔29	ID address #2
	30↔39	ID address #3
	⋮	
	200↔209	ID address #20
	210	ID address #21
	211	ID address #22
	212	ID address #23
	⋮	
	255	ID address #66
11		NO FUNCTION
12		NO FUNCTION

STAGE 2(DMX MODE 1)

CHANNEL	VALUE	FUNCTION
1	0 ↔ 4	DIMMER No function
	5 ↔ 255	0-100%
2	0 ↔ 4	RED No function
	5 ↔ 255	0-100%
3	0 ↔ 4	GREEN No function
	5 ↔ 255	0-100%
4	0 ↔ 4	BLUE No function
	5 ↔ 255	0-100%
5	0 ↔ 9	COLOR MACROS No function
	10 ↔ 29	RED (100%)
	30 ↔ 39	RED+GREEN (R85%+G15%)
	40 ↔ 49	RED+GREEN (R60%+G40%)
	50 ↔ 69	YELLOW (100%)
	70 ↔ 79	RED+GREEN (R15%+G85%)
	80 ↔ 89	RED+GREEN (R40%+G60%)
	90 ↔ 109	GREEN (100%)
	110 ↔ 119	GREEN+BLUE (G85%+B15%)
	120 ↔ 129	GREEN+BLUE (G60%+B40%)
	130 ↔ 149	BLUE (100%)
	150 ↔ 159	BLUE+GREEN (G85%+B15%)
	160 ↔ 169	BLUE+GREEN (G60%+B40%)
	170 ↔ 189	CYAN (100%)
	190 ↔ 199	GREEN+PURPLE (G50%+P50%)
	200 ↔ 219	PURPLE (100%)
220 ↔ 229	PURPLE+GREEN (P80%+G20%)	
230 ↔ 249	RGB (100%)	
250 ↔ 255	WHITE (100%)	
6	0 ↔ 4	STROBE No function
	5 ↔ 255	Strobe (slow to fast)

CHANNEL	VALUE	FUNCTION
7		MODE SELECTION
	0 ↔ 4	No function
	5 ↔ 34	Color-Cycle Mode 1
	35 ↔ 64	Color-Cycle Mode 2
	65 ↔ 94	Color-Cycle Mode 3
	95 ↔ 124	Color-Cycle Mode 4 (speed can be adjusted using Channel 11)
	125 ↔ 154	Color-Cycle Mode 5
	155 ↔ 184	Color-Cycle Mode 6
	185 ↔ 214	Color-Cycle Mode 7
	215 ↔ 244	Color-Cycle Mode 8
	245 ↔ 255	DMX MODE 2
8		ID ADDRESS SELECTION (also see pg. 26)
	0 ↔ 9	Select all ID addresses
	10 ↔ 19	ID address #1
	20 ↔ 29	ID address #2
	30 ↔ 39	ID address #3
	⋮	
	200 ↔ 209	ID address #20
	210	ID address #21
	211	ID address #22
	212	ID address #23
	⋮	
	255	ID address #66
9		MODULE SELECTION
	0 ↔ 4	#1 ON #2 ON #3 ON
	5 ↔ 34	#1 ON
	35 ↔ 64	#2 ON
	65 ↔ 94	#3 ON
	95 ↔ 124	#1 ON #2 ON
	125 ↔ 154	#2 ON #3 ON
	155 ↔ 184	#1 ON #3 ON
	185 ↔ 214	#1 ON #2 ON #3 ON
	215 ↔ 255	#1 OFF #2 OFF #3 OFF
	0 ↔ 255	Speed control of Ch7 Color-Cycle Mode 4
10		EFFECT MACRO
	0 ↔ 4	No function
	5 ↔ 9	Effect MACRO #1
	10 ↔ 14	Effect MACRO #2
	⋮	⋮
	250 ↔ 255	Effect MACRO #50

STAGE 2(DMX MODE 2)

CHANNEL	VALUE	FUNCTION
1	0 ↔ 4	MODULE #1 No function
	5 ↔ 34	RED
	35 ↔ 64	GREEN
	65 ↔ 94	BLUE
	95 ↔ 124	YELLOW
	125 ↔ 154	PURPLE
	155 ↔ 184	CYAN
	185 ↔ 255	PINK-WHITE
2	0 ↔ 4	MODULE #2 No function
	5 ↔ 34	RED
	35 ↔ 64	GREEN
	65 ↔ 94	BLUE
	95 ↔ 124	YELLOW
	125 ↔ 154	PURPLE
	155 ↔ 184	CYAN
	185 ↔ 214	PINK-WHITE
3	0 ↔ 4	MODULE #3 No function
	5 ↔ 34	RED
	35 ↔ 64	GREEN
	65 ↔ 94	BLUE
	95 ↔ 124	YELLOW
	125 ↔ 154	PURPLE
	155 ↔ 184	CYAN
	185 ↔ 214	PINK-WHITE
4		NO FUNCTION
5		NO FUNCTION
6	0 ↔ 4	STROBE No function
	5 ↔ 255	Strobe (slow to fast)
7	0 ↔ 244	MODE SELECTION DMX MODE 1
	245 ↔ 255	DMX MODE 2

CHANNEL	VALUE	FUNCTION
8	0↔9	ID ADDRESS SELECTION (also see pg. 26) Select all ID addresses
	10↔19	ID address #1
	20↔29	ID address #2
	30↔39	ID address #3
	⋮	
	200↔209	ID address #20
	210	ID address #21
	211	ID address #22
	212	ID address #23
	⋮	
	255	ID address #66
9		NO FUNCTION
10		NO FUNCTION

PIXEL

CHANNEL	VALUE	FUNCTION
1~9	0↔4	NO FUNCTION
1	5↔255	BLOCK1-RED
2	5↔255	BLOCK1-GREEN
3	5↔255	BLOCK1-BLUE
4	5↔255	BLOCK2-RED
5	5↔255	BLOCK2-GREEN
6	5↔255	BLOCK2-BLUE
7	5↔255	BLOCK3-RED
8	5↔255	BLOCK3-GREEN
9	5↔255	BLOCK3-BLUE

4.3 BASIC INSTRUCTIONS FOR DMX512 OPERATION

STAGE 1 DMX MODE 1

RED, GREEN & BLUE COLOR SELECTION

- CH1, CH2 & CH3 control the intensity ratio of each of the RED, GREEN & BLUE LEDs.
- When the slider is at the highest position (255) the intensity of the color is the maximum.
- CH1, CH2 & CH3 can be combined together to create over 16 million colors.
- CH1, CH2, CH3 have priority over CH4, CH5, CH6 & CH7

YELLOW, CYAN, PURPLE & WHITE

- CH4, CH5, CH6 & CH7 are independent colors and cannot be mixed with any other color control channel.
- When multiple channels are used at the same time; lower channel number is priority (i.e. CH4 has priority over all channels 1-6)

STROBE

- CH8 is the strobe channel and controls the strobe effects of CH1, CH2, CH3, CH4, CH5, CH6, & CH7
- The strobe is with an adjustable speed with a maximum of 20Hz.
- The strobe is not active with CH9 & CH12

MODE SELECTION

- CH9 allows the user to activate DMX MODE 1 (0-244) or DMX MODE 2 (245-255).
- CH9 values 5-244 can only be activated when CH1 to CH7 are not activated
- When Color-Cycle Mode 4 is selected CH11 controls the speed of the Color-cycle.

ID ADDRESS SELECTION

- CH10 is used to select the target ID address.
- Each independent DMX address may have up to 66 independent ID addresses.
- An ID address of 0 will be activated by all ID address locations.

MODULE SELECTION

- CH11 controls set combinations of the three LED MODULES present in each unit.
- CH11 has priority over CH12 when first activated

EFFECT MACRO

- The effect MACRO channel allows the user to select from combinations of different colors and LED modules in a quick-and-easy action.
- CH12 has priority over color control channels (CH1, CH2, CH3, CH4, CH5, CH6 & CH7)
- CH12 has priority over CH11 when first activated
- CH12 has priority over CH9 & CH11

STAGE 1 DMX MODE 2

MODULE #1, MODULE #2 & MODULE #3 SELECTION

- CH1, CH2 & CH3 allow quick-and-simple control of the three LED MODULES
- Control of the LED MODULES can be used in conjunction with all other channels in DMX MODE 2

STROBE

- CH8 is the strobe channel and controls the strobe effects of CH1, CH2 & Ch3
- The strobe is with an adjustable speed with a maximum of 20Hz.

MODE SELECTION

- CH9 allows the user to activate DMX MODE 1 (0-244) or DMX MODE 2 (245-255).

ID ADDRESS SELECTION

- CH10 is used to select the target ID address.
- Each independent DMX address may have up to 66 independent ID addresses.

STAGE 2 DMX MODE 1

DIMMER

- CH1 control the dimmer intensity of Ch2, Ch3, Ch4, Ch5, Ch6 & Ch9.
- When Ch1 is set to 0, Ch2, Ch3, Ch4, Ch5, Ch6 & Ch9 no function..
- When the slider is at the highest position (255) the dimmer intensity is the maximum.
- CH1 has priority over Ch7 when first activated.

RED, GREEN & BLUE COLOR SELECTION

- CH2, Ch3 & CH4 control the intensity ratio of each of the RED, GREEN & BLUE LEDs.
- When the slider is at the highest position (255) the intensity of the color is the maximum.
- CH2, Ch3 & CH4 can be combined together to create over 16 million colors.

COLOR MACRO

- The COLOR MACRO channel allows the user to select from different color macro.
- Ch5 has priority over Ch2, Ch3 & Ch4.

STROBE

- CH6 is the strobe channel and controls the strobe effects of CH2, CH3, Ch4, CH5 & CH9
- The strobe is with an adjustable speed with a maximum of 20Hz.
- The strobe is not active with CH7 & CH10

MODE SELECTION

- CH7 allows the user to activate DMX MODE 1 (0-244) or DMX MODE 2 (245-255).
- Ch7 has priority over Ch1 when first activated.
- Ch7 has priority over Ch10 when first activated.
- When Color-Cycle Mode 4 is selected Ch9 controls the speed of the Color-cycle.

ID ADDRESS SELECTION

- CH8 is used to select the target ID address.
- Each independent DMX address may have up to 66 independent ID addresses.
- An ID address of 0 will be activated by all ID address locations.

MODULE SELECTION

- Ch9 controls set combinations of the three LED MODULES present in each unit.

EFFECT MACRO

- The effect MACRO channel allows the user to select from combinations of different colors and LED modules in a quick-and-easy action.
- CH10 has priority over CH1.
- CH10 has priority over Ch7 when first activated

STAGE 2 DMX MODE 2

MODULE #1, MODULE #2 & MODULE #3 SELECTION

- CH1, CH2 & CH3 allow quick-and-simple control of the three LED MODULEs
- Control of the LED MODULEs can be used in conjunction with all other channels in DMX MODE 2

STROBE

- CH6 is the strobe channel and controls the strobe effects of CH1, CH2 & Ch3
- The strobe is with an adjustable speed with a maximum of 20Hz.

MODE SELECTION

- CH7 allows the user to activate DMX MODE 1 (0-244) or DMX MODE 2 (245-255).

ID ADDRESS SELECTION

- CH8 is used to select the target ID address.
- Each independent DMX address may have up to 66 independent ID addresses.

ARC 1 MODE

RED, GREEN & BLUE COLOR SELECTION

- CH1, Ch2 & CH3 control the intensity ratio of each of the RED, GREEN & BLUE LEDs.
- When the slider is at the highest position (255) the intensity of the color is the maximum.
- CH1, Ch2 & Ch3 can be combined together to create over 16 million colors.

PIXEL

Every color in each module used as one pixel.

For example, in module #1:

12 red leds = one pixel

12 green leds = one pixel

12 blue leds = one pixel

4.4 PROGRAMMING WITH A DMX512 CONTROLLER: EXAMPLES(STAGE 1)

EXAMPLE 1

Before any operation is performed on the DMX512 controller, confirm that all DMX channels are set to zero.

NOTE

When programming a step / scene that involves operating CH10 to select an ID address, this channels operation should be performed first

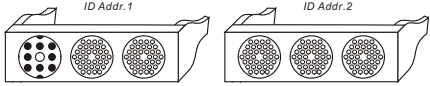
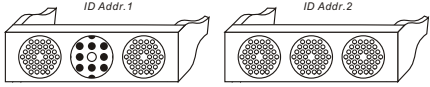
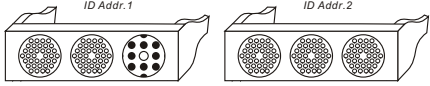
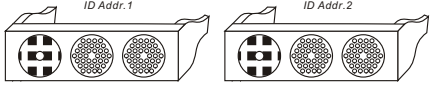
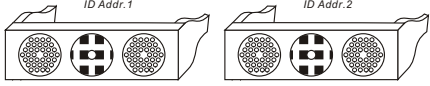
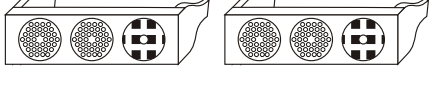
Step 1	CH1	20	to select RED for MODULE #1 (ID Add. 1)	
	CH2	0	to select OFF for MODULE #2 (ID Add. 1)	
	CH3	0	to select OFF for MODULE #3 (ID Add. 1)	
	CH9	255	to select DMX mode 2	
	CH10	11	to select ID Add. 1	
Step 2	CH1	0	to select OFF for MODULE #1	
	CH2	20	to select RED for MODULE #2 (ID Add. 1)	
	CH3	0	to select OFF for MODULE #3 (ID Add. 1)	
	CH9	255	to select DMX mode 2	
	CH10	11	to select ID Add: 1	
Step 3	CH1	0	to select OFF for MODULE #1 (ID Add. 1)	
	CH2	0	to select OFF for MODULE #2	
	CH3	20	to select RED for MODULE #3 (ID Add. 1)	
	CH9	255	to select DMX mode 2	
	CH10	11	to select ID Add: 1	
Step 4	CH1	50	to select GREEN for MODULE #1 (ID Add. 1 & ID Add. 2)	
	CH2	0	to select OFF for MODULE #2 (ID Add. 1 & ID Add. 2)	
	CH3	0	to select OFF for MODULE #3	
	CH9	255	to select DMX mode 2	
	CH10	0	to select all ID Addresses	
Step 5	CH1	0	to select OFF for MODULE #1 (ID Add. 1 & ID Add. 2)	
	CH2	50	to select GREEN for MODULE #2 (ID Add. 1 & ID Add. 2)	
	CH3	0	to select OFF for MODULE #3 (ID Add. 1 & ID Add. 2)	
	CH9	255	to select DMX mode 2	
	CH10	0	to select all ID Addresses	
Step 6	CH1	0	to select OFF for MODULE #1 (ID Add. 1 & ID Add. 2)	
	CH2	0	to select OFF for MODULE #2 (ID Add. 1 & ID Add. 2)	
	CH3	50	to select GREEN for MODULE #3 (ID Add. 1 & ID Add. 2)	
	CH9	255	to select DMX mode 2	
	CH10	0	to select all ID Addresses	



Red Green Blue

EXAMPLE 2

Before any operation is performed on the DMX512 controller, confirm that all DMX channels are set to zero.

Step 1	CH1	255	to select RED for all MODULES (ID Add. 1)	
	CH2	0	to select NOGREEN for allMODULES (ID Add.1)	
	CH3	0	to select NOBLUE for allMODULES (ID Add.1)	
	CH9	0	to select DMX mode 1	
	CH10	11	to select IDAdd. 1	
Step 2	CH1	0	to select OFF for all MODULES (ID Add. 1)	
	CH2	0	to select NOGREEN for allMODULES (ID Add.1)	
	CH3	0	to select NOBLUE for allMODULES (ID Add.1)	
	CH9	0	to select DMX mode 1	
	CH10	11	to select IDAdd: 1	
Step 3	CH1	0	to select NORED for allMODULES (ID Add.2)	
	CH2	0	to select NOGREEN for allMODULES (ID Add.2)	
	CH3	255	to select BLUE for all MODULES (IDAdd. 2)	
	CH9	0	to select DMX mode 1	
	CH20	12	to select IDAdd: 2	
Step 4	CH1	0	to select NOGREEN for allMODULES (ID Add.1 & IDAdd.2)	
	CH2	50	to select GREEN for all MODULES (ID Add.1 & IDAdd.2)	
	CH3	0	to select NOGREEN for allMODULES (ID Add.1 & IDAdd. 2)	
	CH9	0	to select DMX mode 2	
	CH10	20	to select all ID Addresses	
Step 5	CH1	0	to select OFF for MODULE #1 (ID Add. 2)	
	CH2	0	to select GREEN for MODULE #2 (ID Add. 2)	
	CH3	0	to select OFF for MODULE #3 (ID Add.1)	
	CH9	0	to select DMX mode 2	
	CH10	0	to select IDAdd: 2	
Step 6	CH1	20	to select RED for MODULE #1 (ID Add. 2)	
	CH2	50	to select GREEN for MODULE #2 (ID Add. 2)	
	CH3	80	to select BLUE for MODULE #3 (ID Add. 2)	
	CH9	0	to select DMX mode 2	
	CH10	12	to select IDAdd: 2	



Step 7	CH1	0	to set OFF for MODULE #1 (ID Add. 1)	
	CH2	0	to select OFF for MODULE 2 (ID Add. 1)	
	CH3	0	to select OFF for MODULE 3 (ID Add. 1)	
	CH9	0	to select DMX mode 1	
	CH10	11	to select ID Add. 1	
Step 8	CH1	255	to select RED for all MODULES (ID Add. 2)	
	CH2	0	to select NOGREEN for all MODULES (ID Add. 2)	
	CH3	0	to select NOBLUE for all MODULES (ID Add. 2)	
	CH9	0	to select DMX MODE 1	
	CH10	12	to select ID Add: 2	



EXAMPLE 3

Before any operation is performed on the DMX512 controller, confirm that all DMX channels are set to zero.

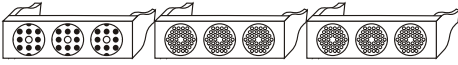
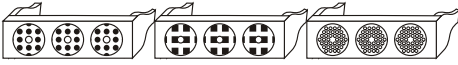
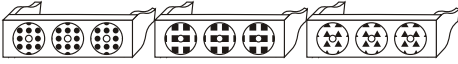
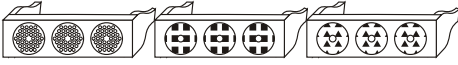
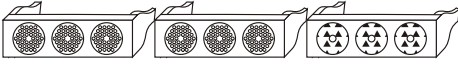
Step 1	CH1	255	to select RED for all MODULES (ID Add. 1)	
	CH2	0	to select NO GREEN for all MODULES (ID Add. 1)	
	CH3	0	to select NO BLUE for all MODULES (ID Add.1)	
	CH9	0	to select DMX mode 1	
	CH10	11	to select IDAdd. 1	
Step 2	CH1	0	to select NO RED for all MODULES (ID Add.2)	
	CH2	255	to select GREEN for all MODULES (ID Add.2)	
	CH3	0	to select NO BLUE for all MODULES (ID Add. 2)	
	CH9	0	to select DMX mode 1	
	CH10	12	to select IDAdd: 2	
Step 3	CH1	0	to select NO RED for all MODULES (ID Add.3)	
	CH2	0	to select NO GREEN for all MODULES (ID Add.3)	
	CH3	255	to select BLUE for all MODULES (ID Add.3)	
	CH9	0	to select DMX mode 1	
	CH10	13	to select IDAdd: 3	
Step 4	CH1	0	to select NO RED for all MODULES (ID Add.1)	
	CH2	0	to select NO GREEN for all MODULES (ID Add.1)	
	CH3	0	to select NO BLUE for all MODULES (ID Add.1)	
	CH9	0	to select DMX mode 1	
	CH10	11	to select IDAdd. 1	
Step 5	CH1	0	to select NO RED for all MODULES (ID Add.2)	
	CH2	0	to select NO GREEN for all MODULES (ID Add.2)	
	CH3	0	to select NO BLUE for all MODULES (ID Add.2)	
	CH9	0	to select DMX mode 1	
	CH10	12	to select IDAdd: 2	



5 APPENDIX

5.1 TROUBLE SHOOTING

LED MODULE

SITUATION	CAUSE	ACTION	PART ORDER NUMBER
No display	1) Power connection error	1) Check all power connections	
	2) Main PCB fuse overheated	2) Replace fuse	16-03-0020-03
	3) Main PCB damaged	3) Replace main PCB	26-2A-LED301MD4-00
LED MODULE on, but no control from display	Display board damaged	Replace display board	26-2A-LED301DI-01
LEDs of the same color are not lit	LED PCB damaged	Replace PCB board	26-2A-LED301Light-00
LEDs of all colors are not lit	Main PCB damaged	Replace main PCB	26-2A-LED301MD4-00
Display normal, but no response to DMX512 controller	1) Signal connection error	1) Check all signal connections	
	2) DMX address error	2) Check DMX address setting	